

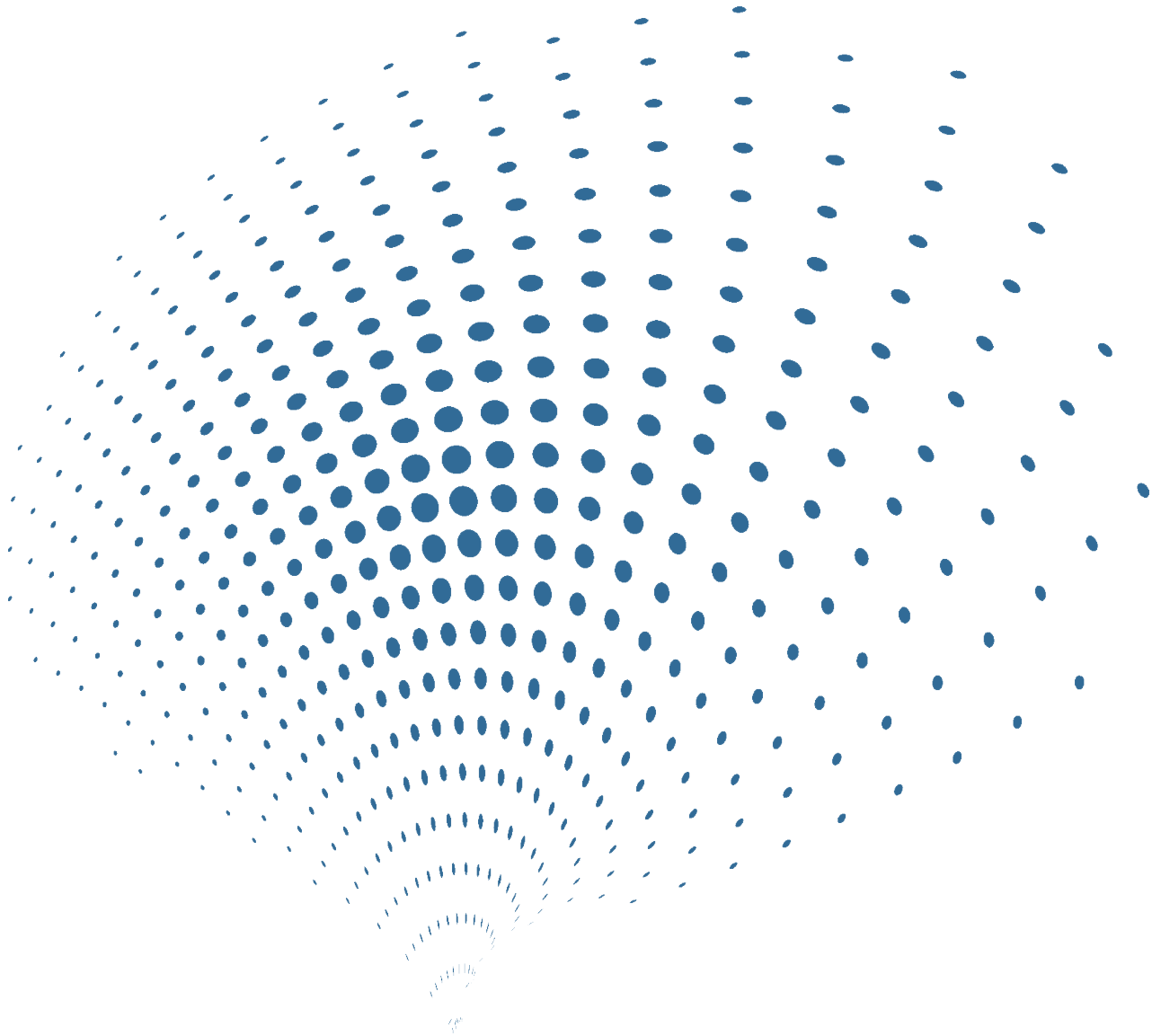

Vigor Technology



## **CAN Inclinometer**

# CAN Inclinometer

## Features

- ISO11898-2 standard, twisted-pair output
- Protocol stack follows CAN2.0A, CAN2.0B
- Built-in high-speed optoelectronic isolation
- Support 5K-1000Kbps total 15 kinds of CiA recommended
- Baud rate
- Distance achieves 10 Km, can connect 127 units
- Patent, Real high accuracy tilt measurement



## Descriptions

CAN inclinometer is based on Vigor patent tilt measurement technology and combined with CAN module, according to high reliability & stability evaluation methodology of military/ aerospace application. It focus to various industrial measuring and control system of PLC/DAQ applications. Not only meet to critical null repeatability, also suite to static/dynamic leveling with different optional modules in platform leveling application. With real high combined accuracy, this unit performs high accuracy data of any angle point.

CAN inclinometer except meet ISO11898-2 standard, furthermore has strong measuring ability:

- ✓  $\pm 0.02\%$ FS linearity
- ✓  $\pm 0.005^\circ$  Offset
- ✓ Combine with gyro module, realize static/dynamic angle measuring for low/rapid leveling.
- ✓ With vibration module, realize FFT computations in-time, output vibration frequency and amplitude data directly, eliminate the influence of environment vibration
- ✓ Combine with GPS module, realize data synchronization data acquisition and local position data in different installation places
- ✓ Further confirmed that offset/repeatability/hysteresis/turn on repeatability etc. parameters which are important influence factors to total performance evaluation
- ✓ Internal enhanced advanced intelligent algorithms drastically reduce cross-axis error. upgrades real tilt angle measuring accuracy, abandoned the traditional incomplete understanding for tilt angle measurement accuracy concept
- ✓ Greatly reduce measuring errors when the real tilt direction not consistent for unit's actual sensitive axis
- ✓ Short-circuit, transient voltage, transposition protections to adapt to industry environment
- ✓ User can set unit's all kinds of parameters via CAN interface, and query factory data

CAN inclinometer supports ISO11898-2 slave point standard protocol, point to point or one point to multipoint communication method. Working model supports acknowledge model, continuous sending mode and parameter setting mode. User can setup via CAN interface and set zero point, baud rate, local gravitational acceleration value, zero calibration, vibration suppression filter coefficients, ID address, refresh rate, etc.

CAN transmitting speed is 5kbps~1Mbps. Support 127 nodes in single network on a twisted-pair cable, maximum load line length is 10km. By kinds of recommend options (CAN-Fiber converter, etc.) can maintain high speed data rate with longer communication distance.

C13 cable option is a  $120\Omega$  dedicated twisted-pair cable based on the characteristic impedance of CAN specification. It includes proprietary 100% aluminum foil shield and 65% tinned copper braid shield, with maximum shielding effect. It is capable of carrying PLTC listed signal of UL NEC Type, installation flexibility. Meanwhile, in order to meet request of real on-site adjustment and display, Vigor provides specialized CAN connector LED indicator, can realize the function of parameter setting, alarm point setting, angle value displaying, etc.

# Performances

Table 1 Specifications

Measurement range	±5°	±10°	±15°	±30°	±45°	±60°	
Combined absolute accuracy <sup>①</sup> (@25°C)	±0.01°	±0.015°	±0.02°	±0.04°	±0.06°	±0.08°	
Accuracy subroutine parameter	Absolute linearity (LSF,%FS)	±0.06	±0.03	±0.03	±0.03	±0.02	±0.02
	Cross-axis sensitivity <sup>②</sup>	±0.1%FS					
	Offset <sup>③</sup>	±0.005°			±0.008°		
	Repeatability	±0.0025°					
	Hysteresis	±0.0025°					
Allowed installation misalignment <sup>④</sup>	±4.0°	±3.0°	±2.5°	±1.5°	±1.2°	±1.2°	
Input-axis mislignment	≤±0.1°						
Sensitivity temperature drift coefficient(max.)	≤100ppm/°C	≤50ppm/°C					
Offset temperature drift coefficient(max.)	≤0.003°/°C						
Offset turn on repeatability <sup>⑤</sup>	±0.008°						
Resolution	0.0025°						
Long-term stability(1 year)	≤0.02°						
Measurement axis	1 or 2 axis						
Temperature sensor	Range: -50~125°C , Accuracy: ±1°C						
Output	CAN2.0A, CAN2.0B, follow ISO11898-2 standard						
	5k~1 MBit/s, 15 kinds of CiA recommended Baud rate						
Function	Through CAN interface set and adjust zero point , Baud rate, local Gravitational acceleration value, zero correction, vibration suppression filter coefficients, ID address , refresh rate, etc.						
Cold start warming time	60s						
Response time	0.3s(@t <sub>90</sub> )						
Refresh rate	5Hz, 10Hz, 20Hz						
Response frequency	3Hz @-3dB						
Power supply	9~36VDC						
Power consumption	Average working current≤200mA(25°C&24VDC)						
Operation temperature range	-40~85°C						
Storage temperature range	-60~100°C						
Insulation resistance	100MΩ						
MTBF	≥25000 h/times						
Shock	100g@11ms , three-axis, half-sine						
Vibration	8grms, 20~2000Hz						
Protection	IP65(Optional IP67)						
Connecting	Military class connector (MIL-C-26482)						
Weight	420g (without connector and cable)						

① Combined absolute accuracy means the compositive value of sensor's absolute linearity, repeatability, hysteresis, offset and cross-axis sensitivity error. (In room temperature condition) as

$$\Delta = \pm \sqrt{\text{absolute linearity}^2 + \text{repeatability}^2 + \text{hysteresis}^2 + \text{offset}^2 + \text{cross-axis sensitivity error}^2}$$

② The cross-axis sensitivity means the angle that the tilt sensor may be banked to the normal tilt direction of sensor. The cross-axis sensitivity (±0.1%FS) shows how much perpendicular acceleration or inclination is coupled to the inclinometer output signal. For example, for the single-axis inclinometer with range ±30° (assuming the X-axis as measured tilt direction), when there is a 10° tilt angle perpendicular to the X-axis direction (the actual measuring angle is no change, example as +8.505°), the output signal will generate additional error for this 10° tilt angle, this error is called as cross-axis sensitivity error. SST300's cross-axis sensitivity is 0.1%FS, the extra error is 0.1%×30°=0.03°(max), then real output angle should be +(8.505°±0.03°). In SST300 series, this error has been combined into the absolute accuracy

③ Offset means that when no angle input (such as the inclinometer is placed on an absolute level platform), output of sensor is not equal to zero, the actual output value is zero offset value.

④ Allowed installation misalignment means during the installation, the allow able installation angle deviation between actual tilt direction and sensor's nature measurement direction. In general, when installed, SST300 sensor is required that the measured tilt direction keep parallel or coincident with sensor designated edge, this parameter can be allowed a certain deviation when sensor is installed and does not affect the measurement accuracy.

⑤ Offset turn on repeatability means the repeatability of the sensor in repeated by supply power on-off-on many times.

## Dimensions (mm)

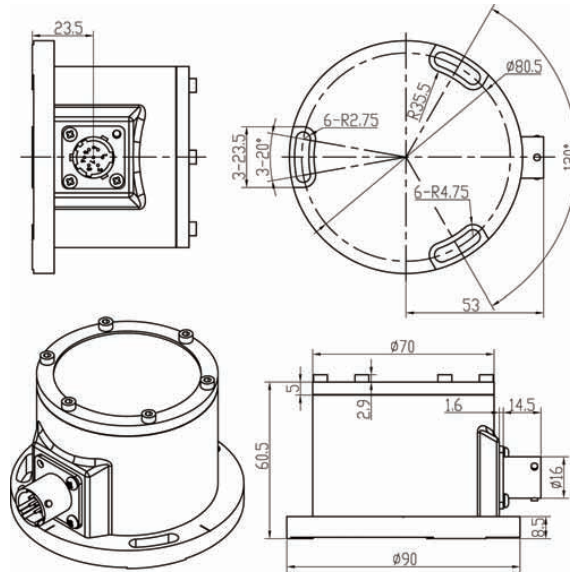

Picture1 Housing with MIL class connector

## Wiring

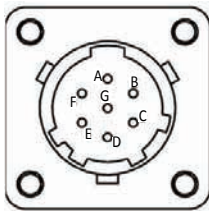

Picture2 MIL connector socket (View from outside)

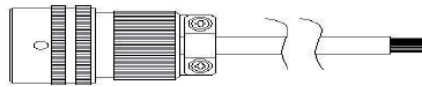

Picture3 Cable/plug(C13)

Table2 CAN pin definition

Pin	Color	Function
A	Red	Power+
B	Black	Power GND
C	Green	NC
D	Yellow	CANH
E	White	CANL
F	Blue	NC
G	Brown	NC

## Ordering

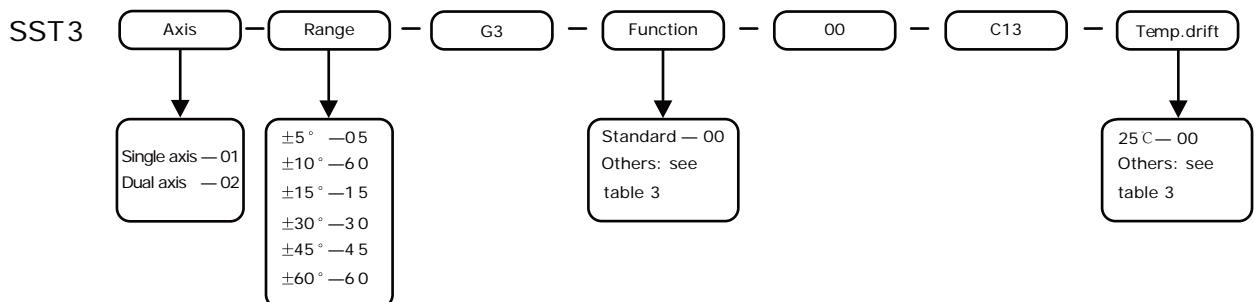

For example, if order a dual axis CAN inclinometer, with range  $\pm 15^\circ$ , room temperature accuracy  $\pm 0.02^\circ$ ,  $-20\text{--}60^\circ\text{C}$  accuracy  $\pm 0.02^\circ$ , output CAN2.0, 25 meters cable with plug, GPS function module, the model should be chosen as: SST302-15-G3-F1-00-C13-D3 (25m)

Other options (see table 4):

PC application software —order number SST003-04-09

Magnetic base—order number SST003-01-01

## Accessories & Options

Table 3 Accessories

Item	Order Code	Accessories name	Function
Functional module (built-in)	F1	GPS module	Positioning accuracy 2.5m CEP; 2.0m @ SBAS Local gravity acceleration automatic revision Time pulse accuracy: 30ns RMS Original data refresh rate: 4Hz Speed accuracy: 0.1m/s Receiver type: GPS L1 band, C/A code; Higher positioning accuracy GPS available
	F4	Gyro module	$\pm 100/250/400^\circ/s$ , X/Y/Z axis dynamic angular rate In-run bias: $\pm 0.02^\circ/s$ , Non-linearity: 0.1%FS Bandwidth: 50Hz, Noise density : $0.02^\circ/s/\sqrt{Hz}$ Higher accuracy gyro module available
	F5	Vibration module	Three-axis vibration detection, frequency response $\leq 5$ kHz Range: 0g $\sim$ $\pm 1g/ \pm 5g/ \pm 10g/ \pm 20g$ , adjustable Sampling(real-time): 20.48 kSPS Filter programmable, 11pcs set points FFT, 512-point, real valued, all three-axis(x, y, z) Storage: 14 FFT records on all three-axis(x, y, z) Alarm programmable, 6 spectrums
Cable/Plug	C13	Military connector with cable	Military class connector(meet MIL-C-26482), Standard 2M CAN/CANOPE cable, IP67 protection, heavy duty up to 30kg
Temperature drift	D1	Temperature drift	Temperature compensation range 0 $\sim$ 60 $^\circ$ C, accuracy $\pm 0.01^\circ @ \leq \pm 30^\circ$
	D2	Temperature drift	Temperature compensation range 0 $\sim$ 60 $^\circ$ C, accuracy $\pm 0.01^\circ @ > \pm 30^\circ$
	D3	Temperature drift	Temperature compensation range -20 $\sim$ 60 $^\circ$ C, accuracy $\pm 0.02^\circ @ \leq \pm 30^\circ$
	D4	Temperature drift	Temperature compensation range -20 $\sim$ 60 $^\circ$ C, accuracy $\pm 0.02^\circ @ > \pm 30^\circ$
	D5	Temperature drift	Temperature compensation range -30 $\sim$ 60 $^\circ$ C, accuracy $\pm 0.03^\circ @ \leq \pm 30^\circ$
	D6	Temperature drift	Temperature compensation range -30 $\sim$ 60 $^\circ$ C, accuracy $\pm 0.03^\circ @ > \pm 30^\circ$
	D7	Temperature drift	Temperature compensation range -40 $\sim$ 65 $^\circ$ C, accuracy $\pm 0.05^\circ @ \leq \pm 30^\circ$
	D8	Temperature drift	Temperature compensation range -40 $\sim$ 65 $^\circ$ C, accuracy $\pm 0.05^\circ @ > \pm 30^\circ$
	D9	Temperature drift	Temperature compensation range -40 $\sim$ 85 $^\circ$ C, accuracy $\pm 0.05^\circ @ \leq \pm 30^\circ$
	D10	Temperature drift	Temperature compensation range -40 $\sim$ 85 $^\circ$ C, accuracy $\pm 0.05^\circ @ > \pm 30^\circ$

Table 4 Options

Item	P/N	Option name	Function
Software	SST003-04-09	PC application software	Setting function, Command function, Tool function Operating platform: windows XP, Windows 7 More information please see datasheet of this options
Indicator	SST003-04-18	CAN indicator	Power supply: 10 $\sim$ 35VDC Communication protocol: ISO 11898, Baud rate: 10 $\sim$ 1000kb/s LED: 15 mm high, range - 99999 $\sim$ 999999 Size: 96x48x120 mm
Converter	SST003-05-02	RS232-CAN converter	Bidirectional communication of CAN and RS-232 CAN-bus circuit adopts DC 2500V electric isolation Support CAN2.0A/B protocol, follow ISO/DIS 11898 Provide three kinds of data conversion models: transparent conversion, transparent identity conversion, Modbus protocol conversion.
	SST003-05-16	CAN—Multimode fiber converter	Completely compatible ISO11898 standard Optical wavelength: 1310nm; 110 nodes; CAN port max. distance : 5000m, SC-PC transmission distance 20 $\sim$ 100 km;
	SST003-05-17	CAN—Single-mode fiber converter	Completely compatible ISO11898 Fiber: single-mode 62.5/125 $\mu$ m, wavelength 1310nm ; Load capacity supports 110 nodes; CAN port max. distance : 5000m, SC-PC transmission distance 20 $\sim$ 100 km;
Installation	SST003-01-01	Magnetic base	50kg suction, permanent magnet, stainless steel materials

---

## Shanghai Vigor Technology Development Co., Ltd.

Tel:021-58404921    Fax:021-58354552    Website: [www.vigordigital.com](http://www.vigordigital.com)  
Address: Room 102, Block 4, No. 289 of Bisheng Road, Shanghai, China